

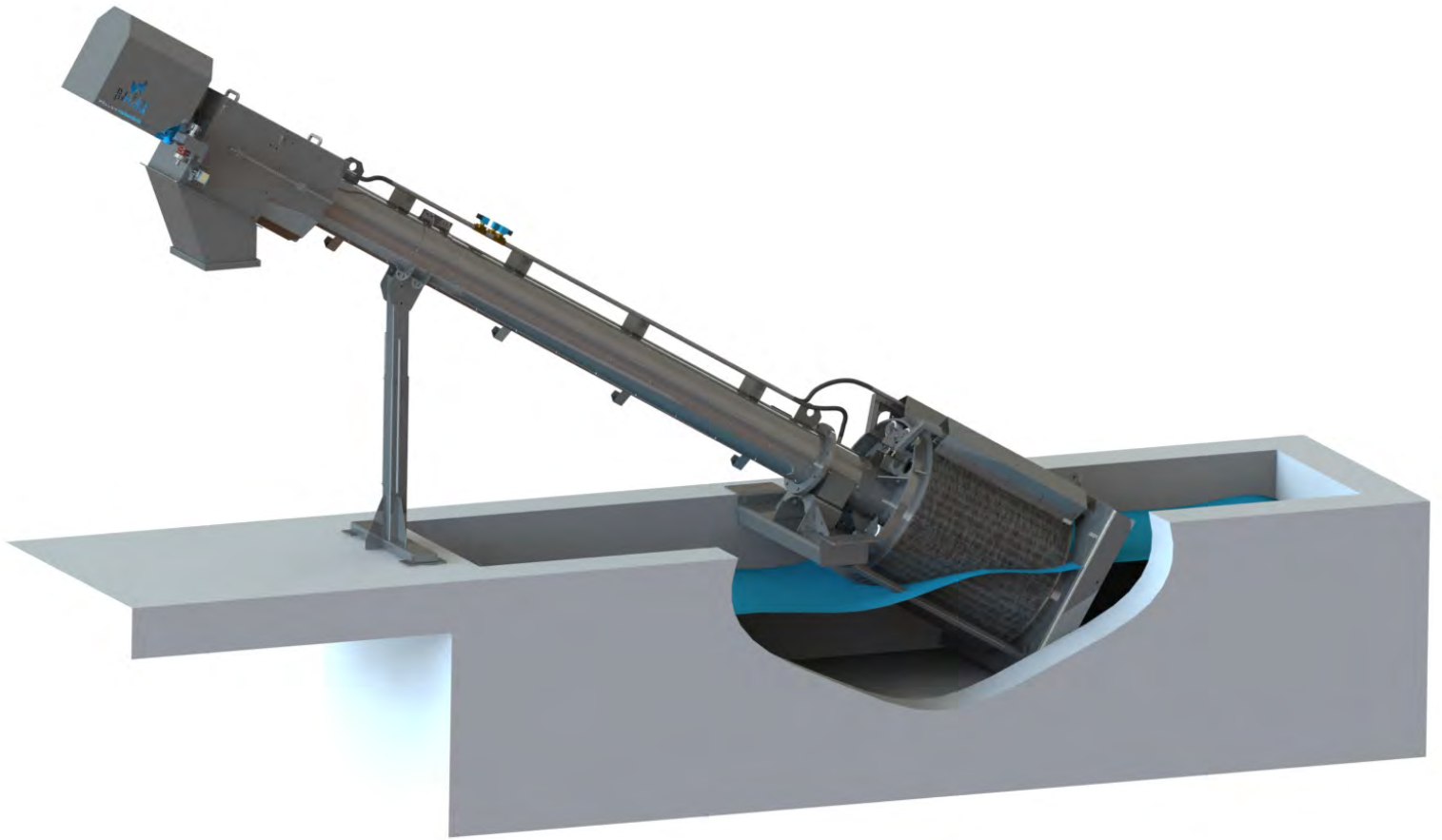

INWARD FLOW SCREW DRUM SCREENS



www.baharmuhendislik.com



INWARD FLOW SCREW DRUM SCREENS

General Description and Intended Use

The inward flow screw drum screens are mechanical equipment designed to remove undesired solids from the water received with wastewater. It removes the solid materials of which particle sizes are larger than grab screen gap ($\text{Ø}2 \text{ mm} - \text{Ø}8 \text{ mm}$ in general).

The inward flow screw drum screens captures small particles and minimize the blockage and breakdowns which may occur in the pumps, valves and pipes. Also, decreasing of the pollution load of the wastewater helps to perform the treatment in lower costs.

The inward flow screw drum screens are assembled at the bottom of the channel with an inclination of $30^\circ - 40^\circ$.

Working Principle Of Equipment

The wastewater is taken to a rotating perforated drum. The solid materials in the wastewater is removed thanks to the perforated surface of the drum. The wastes is transferred into the screw with the rotating drum. The wastes grabbed on the screen surface are carried up thanks to rotating screw. Thanks to pitch gaps of the screw manufactured in different sizes, the wastes are carried up and pressed. The waste volume is decreased and the water in the waste is taken thanks to pressing. The pressing section manufactured from perforated sheet metal is positioned in front of the waste discharge chute. There is no screw in the pressing section. Maximum volume decreasing and dewatering are provided with the pressing effect. The wastes grabbed are cleaned of organic materials by being washed thanks to the nozzles in the pressing section and on the screw. Thus, the bad odors which may be occurred in the screen wastes are prevented. Thanks to the nozzles on the drum screen surface, the solid wastes on the drum are transferred to the screw and the drum is prevented to get blocked. Generally, it consists of a carrier main frame, a drum screen, a screw, a pressing section and a drive group.

Technical Specifications

- It is manufactured in any capacity and size.
- The wastes transferred to the waste discharge part are pressed to reduce their volume and thus, the transportation and disposing costs are reduced.
- It is designed and manufactured for angled assembling.
- It is automatically operated depending on the water level in the screen channel or time without needing an operator.
- A torque switch are available for the safety of the employees and the equipment. In case of excessive loading or compulsion in the equipment, the torque switch gets active and stops the system.
- The nozzle system connected to the solenoid valve sprays clean water to the surface of the screen and the waste discharge unit in order to clean the wastes grabbed of the organic materials.
- When the upper cover is opened, a safety switch which stops the screen is used to provide safety of the employees.
- The inward flow drum screens' upper part over the channel can be manufactured with a cover to prevent bad odors and visual pollution arising out of wastes transferred to the waste discharge unit. The upper covers also provide additional safety in terms of occupational health and safety.



Material Details

- Frame: They can be manufactured as DIN 1.4301 (AISI 304) or DIN 1.4401 (AISI 316).
- Screw: They can be manufactured as DIN 1.4301 (AISI 304), DIN 1.4401 (AISI 316) or S355J0 (St52) + Epoxy Paint.
- Drum Screen Surface: They can be manufactured as DIN 1.4301 (AISI 304) or DIN 1.4401 (AISI 316).
- Cleaning Brush: They can be manufactured from Polyamide.

"Different materials can be preferred in accordance with the request of the customer."

No	Part Name
1	Motor / Reducer
2	Torque Arm
3	Torque Safety System
4	Pressing Area
5	Waste Discharge Chute
6	Assembling Lug - 1
7	Waste Carriage Pipe
8	Assembling Lug - 2
9	Drum Washing Nozzle System
10	Brush
11	Drum Screen Surface
12	Channel Mounting Plate
13	Screw and Drum Bearing

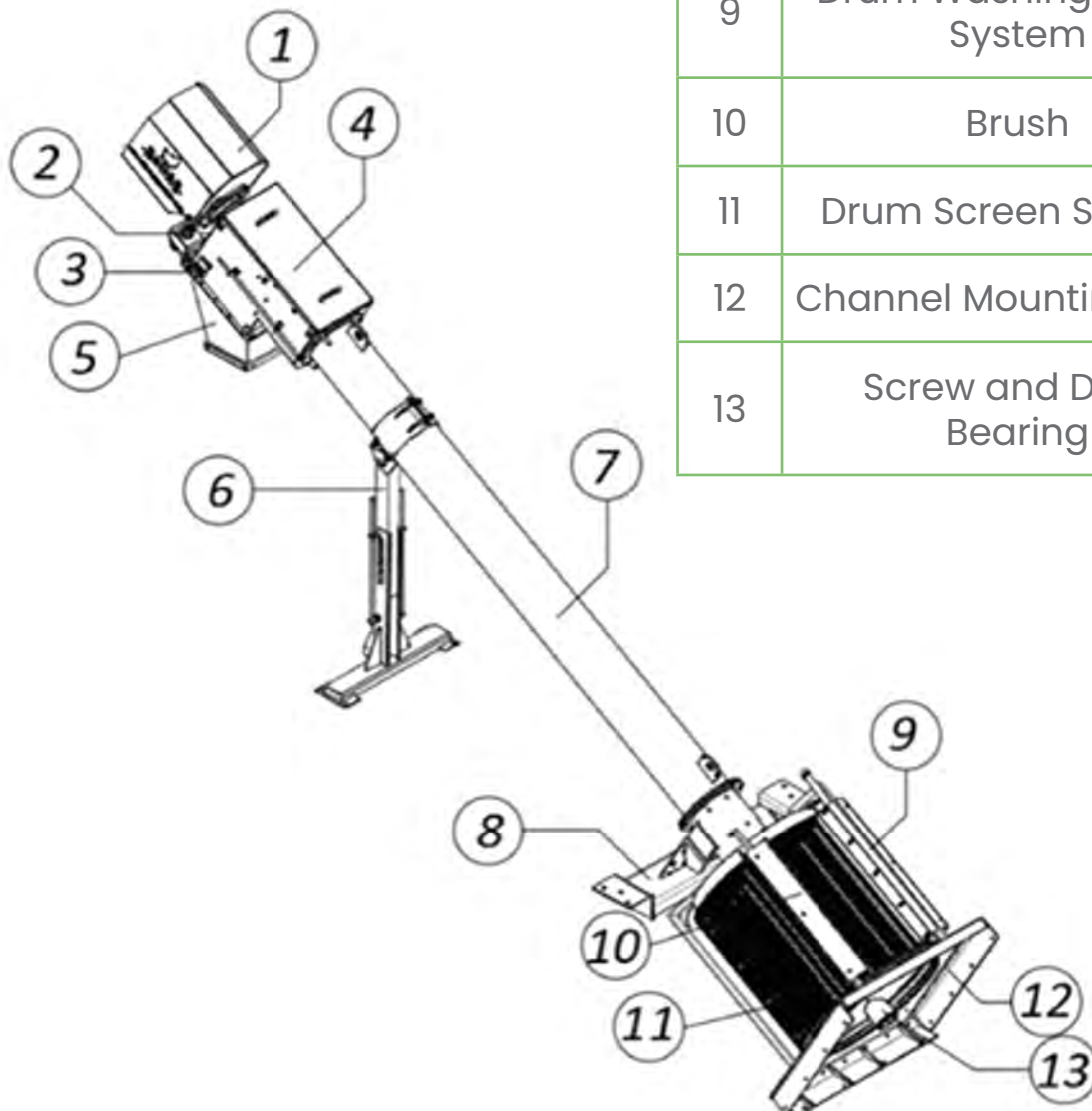

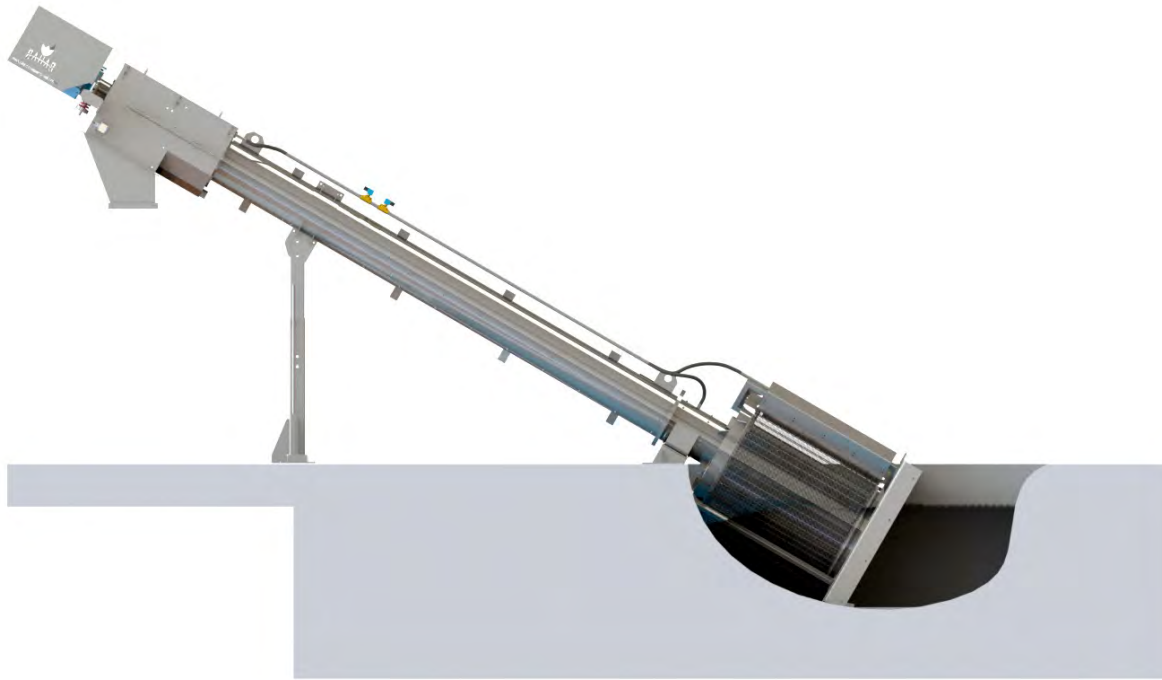

Accessories

- Wash Water Inlet Line Strainer
- Nozzle
- Wash Water Inlet Line Solenoid Valves
- Torque Safety System
- Upper Cover Safety Switch
- Rotatable Waste Inlet Chute*
- Waste Container*
- Emergency Button*
- Level Measuring Sensor*
- Local Power and Control Panel*

* Optional accessories are defined.

Advantages

- High Screening Performance,
- Design Without Requiring an Additional Waste Carriage and Pressing Equipment,
- Possibility to Control and Follow the System Operation Over SCADA,
- Low Energy Consumption,
- Easy Transportation and Mounting,
- Long Operation Life,
- Manufactured From Corrosion Resistant Material,
- Low First Investment Cost,
- Easy to Operate and Maintain,
- Suitable Design for Usage in Small Channels,
- Operation in Higher Flow Rates in Unit Area Compared to Similar Equipment.



BAHAR
BAHAR
mühendislik

Marmaracık Mah. 1982. Sok. No: 13/1
Ergene / Tekirdağ / TÜRKİYE
+90 0282 686 63 33 pbx +90 0282 686 63 34

www.baharmuhendislik.com